

MODEL Z5 DRAIN CLEANING MACHINE - AUTO FEED

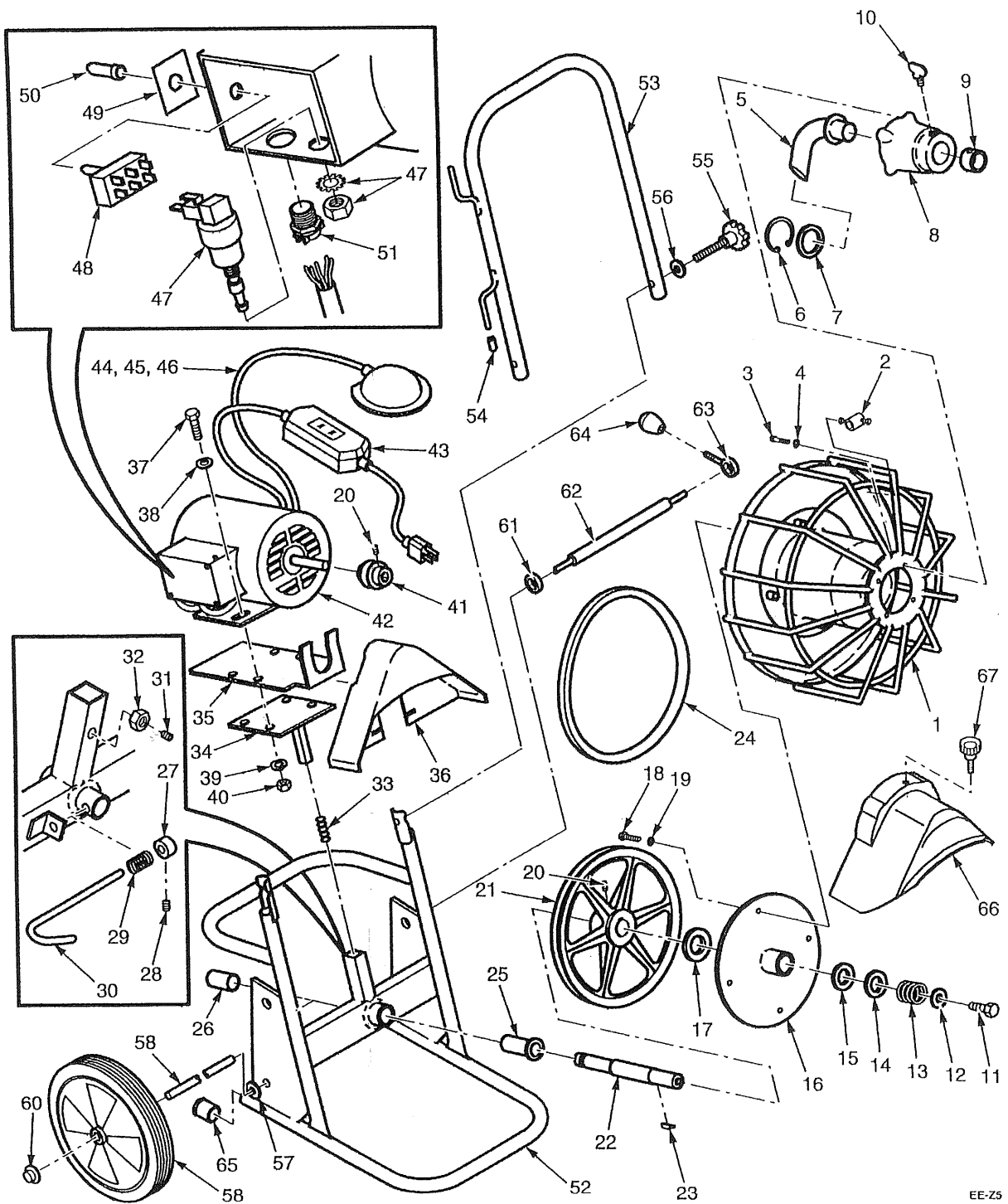

MODEL Z5 DRAIN CLEANING MACHINE - AUTO FEED

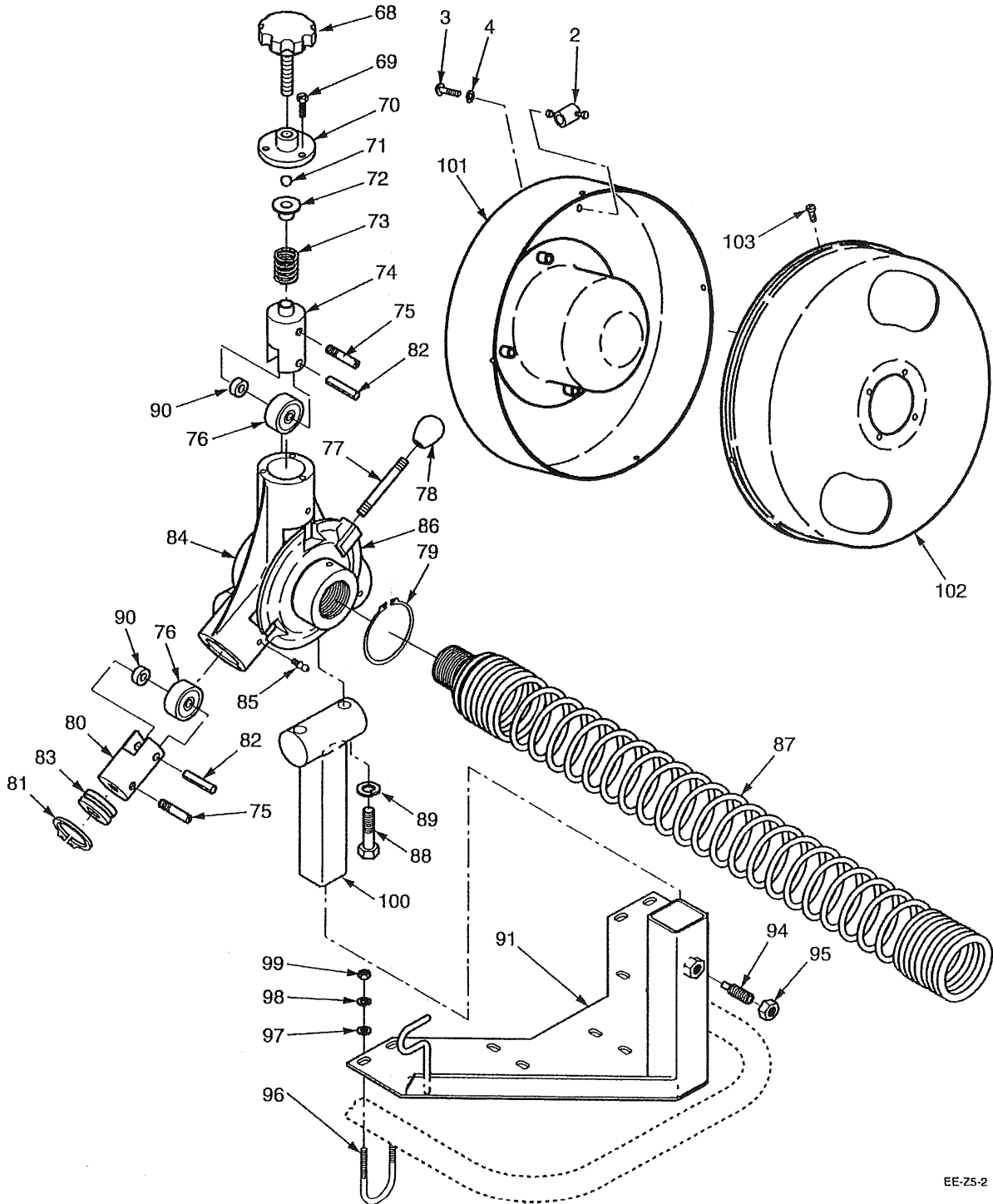

MODEL Z5 DRAIN CLEANING MACHINE - AUTO FEED

ITEM NUMBER	PART NUMBER	DESCRIPTION	AMT
1	Z-6*	Welded Drum/Cage Assembly	1
2	DN-6	Cable Anchor	1
3	MS102412HH	10-24 x 1/2 Hex Head Machine Screw	4
4	LW10	Lockwasher	4
	ED-4A**	Guide Tube and Bracket Assembly	1
5	ED-4	Guide Tube).	1
6	RR175	Retaining Ring	1
7	N-5-4	Retaining Washer	1
8	ED-5	Bracket	1
9	ED-6	Collar.	1
10	WS516	5/16-18 Wing Screw	1
	EE-1A***	Drive Assembly w/Clutch 1	1
11	CSHH12201	1 1/2-20 x 1 Hex Head Capscrew	1
12	WA716P	Flatwasher	1
13	N-14	Spring	1
14	EE-3	Drive Disc	1
15	EE-4	Front Friction Disc	1
16	EE-2	Drum Mounting Plate	1
17	EE-5	Rear Friction Disc	1
18	CSHH142034	1/4-20 x 3/4 Hex Head Capscrew	4
19	LW14	Lockwasher	4
20	SS51618516	5/16-18 x 5/16 Set Screw	2
21	EE-6	10" Pulley).	1
22	EE-1	Drive Shaft	1
23	N-15	Clutch Key.	1
24	4L390	V-Belt).	1
25	0BSF243216	Front Bronze Bushing	1
26	0BSS243220	Rear Bronze Bushing	1
27	EE-8	Retainer Pin Collar	1
28	SS103218	10-32 x 1/8 Set Screw	1
29	EE-15	Retainer Pin Spring.	1
30	EE-7	Retainer Pin.	1
31	SS5162458DP	5/16-24 Set Screw Dog Point	1
32	NU51624FHP	5/16-24 Hex Nut	1
33	EE-9	Motor Tension Spring	1
34	R-23	Motor Mount.	1
35	R-22	Adapter Plate.	1
36	EE-12	Belt Guard	1
37	CSHH516181	Motor Mount Capscrews.	4
38	WA516S	Motor Mount Flatwashers.	4
39	LW516	Motor Mount Lockwasher.	4
40	NU51618FHP	Motor Mount Nuts.	4
41	N-8	Motor Pulley	1
42	EM-1/3	1/3 H.P. Motor w/Fwd-Rev Switch	1

MODEL Z5 DRAIN CLEANING MACHINE - AUTO FEED

ITEM NUMBER	PART NUMBER	DESCRIPTION	AMT
43	GFCI	Ground Fault Circuit Interrupter w/Cord . . .	1
44	FP-1A****	Air Foot Pedal Transmitter w/Air Hose	1
45	FP-1	Foot Pedal Only.	1
46	FP-2	Air Hose Only.	1
47	TBS3218	Air Activated On/Off Switch.	1
48	SW-FR	Forward/Reverse Switch	1
49	SW-FRP	Forward/Reverse Switch Plate	1
50	SW-BOOT	Toggle Switch Boot.	1
51	TSC12	Two-Screw Connector.	1
	Z-1A*****	Frame Assembly	1
52	Z-1	Frame Base	1
53	Z-2A	Frame Handle	1
54	DL6CAP	Cord Hook Cap	2
55	DE-7	Tension Handle	2
56	WA38S	Flatwasher	2
57	WA12S	Flatwasher	8
58	Z-5	Axle	1
59	C-W10	10" Diameter x 5/8 Wheel.	2
60	PN12	Pushnuts	2
61	DF-8	Brake Rod Collar.	1
62	Z-4	Brake Rod	1
63	Z-3	Brake Lever	1
64	DE-14	Brake Lever Knob	1
65	RD1CP16	Cap Plug	2
66	EE-16	Belt Guard	1
67	TS14	Thumb Screw	1
68	FE-4	Tension Handle	1
69	CSSH83212	8-32 x 1/2 Socket Head Cap Screw.	3
70	FE-3	Top Feeder Cap	1
71	BB-38	3/8" Ball Bearing.	1
72	DE-8	Ball Baring Retainer	1
73	FE-5	Tension Spring.	1
74	FE-6	Top Feeder Insert.	1
75	DE-12	Feeder Control Fingers	3
76	FE-7	Feeder Bearing	3
77	DE-13	Control Lever	1
78	DE-14	Control Lever Knob.	1
79	RR168	Retaining Ring	1
80	FE-8	Lower Feeder Insert.	2
81	RR100	Retaining Ring	2
82	RP5161516	5/16 x 1" Roll Pin	3
83	FE-9	Control Bearings	2
84	FE-1	Feeder Body	1
85	GZ1428S	Grease Zerk 1/4-28 Short	3
86	FE-2	Feeder Control Plate	1

MODEL Z5 DRAIN CLEANING MACHINE - AUTO FEED

ITEM NUMBER	PART NUMBER	DESCRIPTION	AMT
87	EZ-GTA	Guide Spring Assembly	1
88	CSHH51618112	5/16-18 x 1 1/2 Hex Head Cap Screw.....	2
89	LW516	5/16 Lockwasher.....	2
90	C145181	Spacer	3
91	EZ-1A	Auto Feed Base.....	1
92	MS83214SS	8-32 x 1/2 Mechine Screw	4
93	ZP-2	Front Cable Drum	1
94	SS5162458DP	5/16-24 x 5/8 Dog Point Set Screw.....	1
95	NU51624FHP	5/16-24 Hex Nut	1
96	UB1420	1/4-20X U Bolt	4
97	WA14S	1/4" Flatwasher.....	4
98	LW14	1/4 Lockwasher.....	4
99	NU1420FHP	1/4-20 Hex Nut	4
100	EZ-2A	Feeder Mounting Post Assy	1
101	ZP-1	Rear Cable Drum w/Inner Drum.....	1
102	MS83214SS	8-32 x 1/2 Mechine Screw	4
103	ZP-2	Front Cable Drum	1

- * Includes Item 2
- ** Includes Items 5-10
- *** Includes Items 11-23
- **** Includes Items 45 and 46
- ***** Includes Items 25-32 and 52-59